

THE LUTE KIT

construction manual

DESIGNED BY John Isaacs and Ian Harwood PRODUCED BY Janine Jackson and Peter Wilder

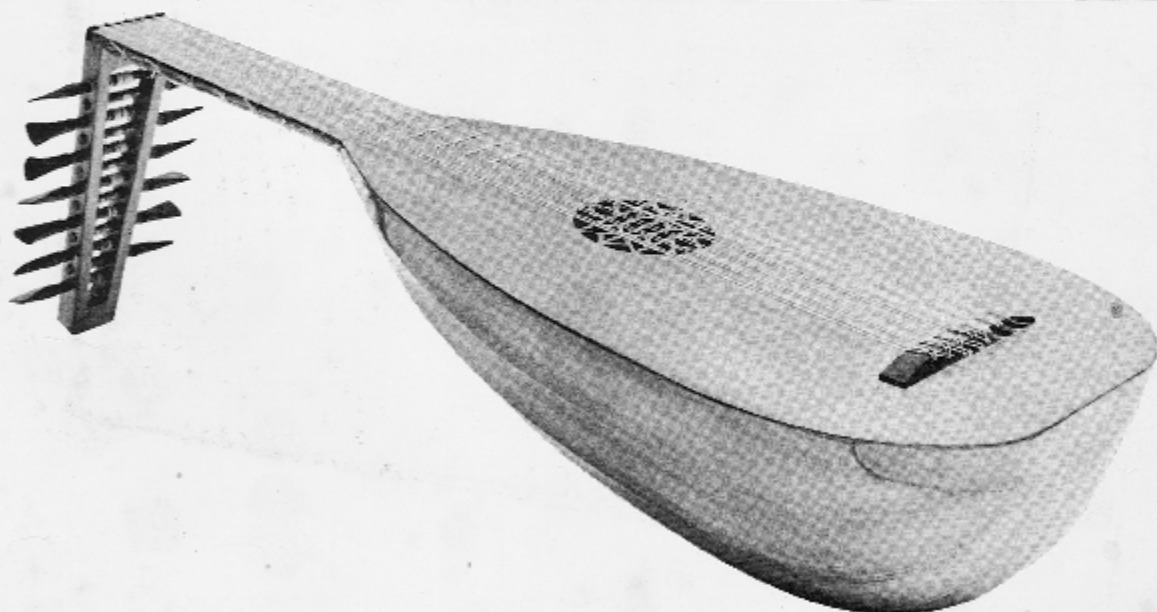

THE LUTE KIT

construction manual

Designed by

IAN HARWOOD and JOHN ISAACS

Produced by

PETER WILDER
Wycombe Road,
Stokenchurch,
High Wycombe, Bucks.

and

JANINE JACKSON
29, Batoum Gardens,
Hammersmith,
London, W.6.

Tel:- 024 026-3455

or

01-603-4173

Illustrations by JANET WILDER.

CONTENTS

	Page
Exploded view of Lute	1
Parts List	2
Photograph of Lute	3
Introduction	4
Introduction	5
ASSEMBLY OF LUTE KIT	
1. Initial Preparation	6
2. Cutting the Ribs	7
3. Sanding the Edges	7
4. Steam-bending the Rib	8
View of first stages of assembly	9
5. Fitting Rib No. 1	10
6. Glueing on Rib No. 1	10
7. Fitting Rib No. 2 followed by No. 8	11
8. Fitting the Last and Central Rib No. 5	12
9. Cleaning up the Back	12
10. Taping the Inside of the Back	12
View of Capping Strip Clamping	13
11. Fitting the Capping Strip	14
12. The Soundboard or Belly	14
13. Marking out the Soundboard	14
14. The Rose	14
15. Putting on the Bridge	15
16. The Bars	15
17. Bending the Bass Bar	15
18. The Length of Bars	16
19. Marking and cutting the Bars	16
20. Glueing on the Bars	17
21. Fitting the Neck to the Back	17
22. Cutting and Fitting the Soundboard to the Back	18
23. Fitting the Pegbox	18
24. The Fingerboard	18
25. The Fretnut	19
26. The Pegs	19
27. Marking out the Fret Positions	20
28. The Final Finishing of the Wood	20
29. Fitting the Nylon Frets	21
30. Stringing	22
31. Tuning	23
32. To check the Tuning	23

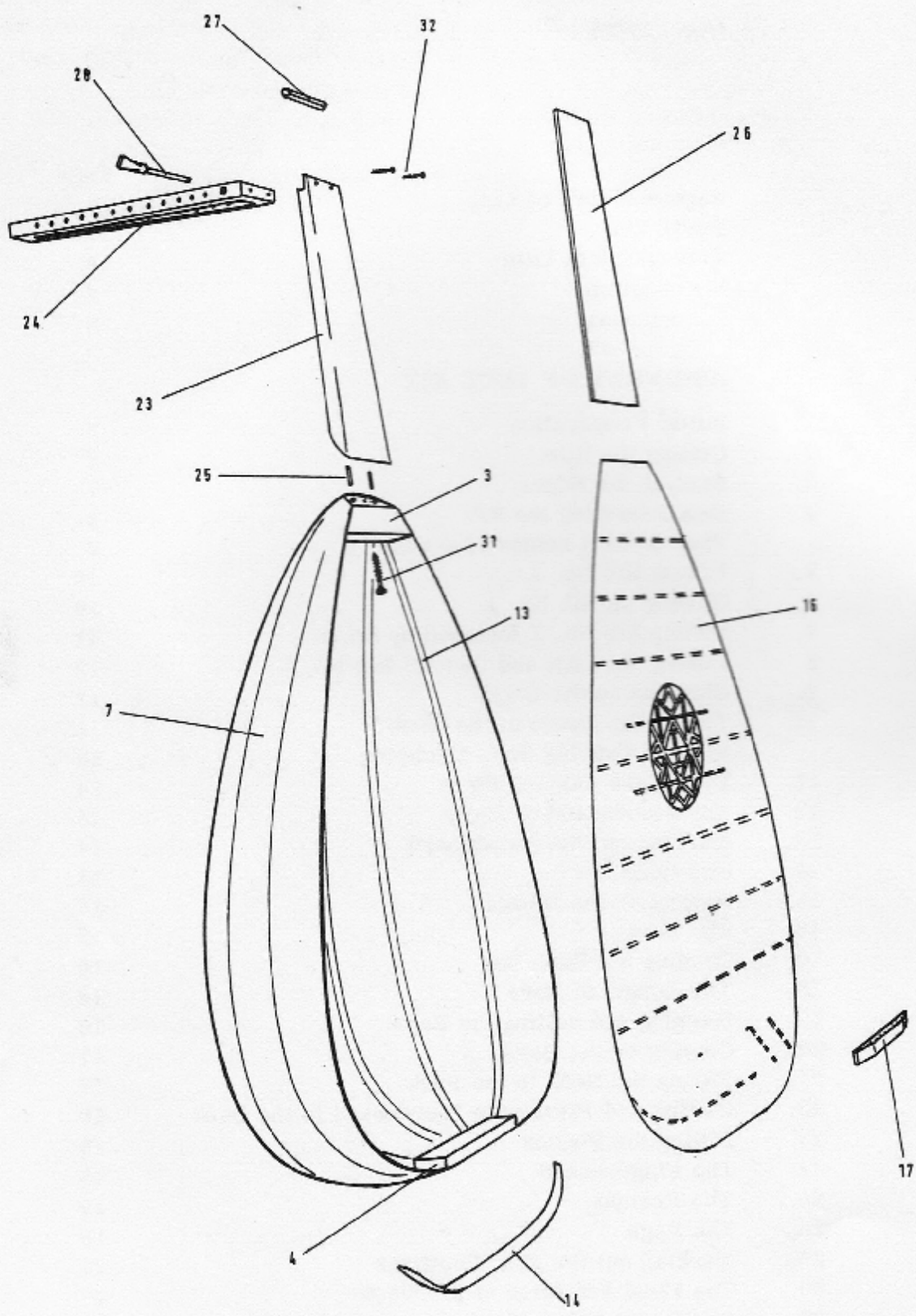

EXPLODED VIEW OF LUTE

PARTS LIST

When you open the package containing your kit, we would be grateful if you would check the parts against the following list. This will also help you to become familiar with them. If there is a part missing, please write to us immediately, and we will forward it to you.

We have included some spare parts in the kit, but if you damage any part in construction, replacements can be obtained

Don't hesitate to phone or write if you have any difficulty in making your lute, we will be very pleased to advise you.

1. Baseboard, 3/8" thick, (9.5 mm) shaped to mould with cut-out for bridge
2. Mould, attached to baseboard.
3. Neck block, attached to baseboard.
4. End block, attached to baseboard.
5. Large neck block clamp.
6. Small neck block clamp.
7. Sycamore or Maple for ribs, 12, 27" x 2 1/4" x 1/16" (685 mm x 57 mm x 1.6 mm)
8. Template for cutting the ribs.
9. Length of laminated scrapwood, 20" long (0.5 m)
10. Piece of tapered plywood to use under neck block clamps, (Segment 'B')
11. Rubber bands, 10 long, 10 medium, 10 short.
12. Wedges for clamping.
13. Length of tape, 16' long (4.875 m) for taping the inside of lute.
14. Capping Strip
15. Plywood packing for use with capping strip, 4" x 1 1/4" x 1/4" (100 x 32 x 6.4 mm)
16. Soundboard, 21" x 12 1/2" x 3/32" (533 mm x 317 mm x 2 mm)
17. Bridge, 5" x 5/8" x 3/8" (127 mm x 16 mm x 9.5 mm)
18. Plywood for clamping bridge
19. Large bar wood, 1" x 1/4" (25.4 mm x 6.4 mm)
20. Medium bar wood, 1/2" x 1/8" (12.7 mm x 3.2 mm)
21. Small bar wood 1/4" x 1/8" (6.4 mm x 3.2 mm)
22. Bar angle marker
23. Neck, - shaped and angled ready for fitting.
24. Peg-box, drilled and reamed.
25. Dowelling, 1/4" x 2 1/2" (6.4 mm x 63 mm)
26. Fingerboard, 9 1/2" x 3 1/8" x 3/32" (241 mm x 80 mm x 2 mm)
27. Fretnut, shaped.
28. Pegs, 13, tapered and drilled.
29. Nylon for frets, 8' long (2.5 m)
30. Strings, 13, Mari, ultra light.
31. Screw for neck block, 2 1/4" (57 mm) No. 10
32. 2 screws for peg-box, 5/8" (16 mm) No. 4
33. Large panel pins, 3/4" (19 mm)
34. Small panel pins, 5/8" (16 mm)
35. Cutting knife and blades.
36. A sheet of full scale working drawings.

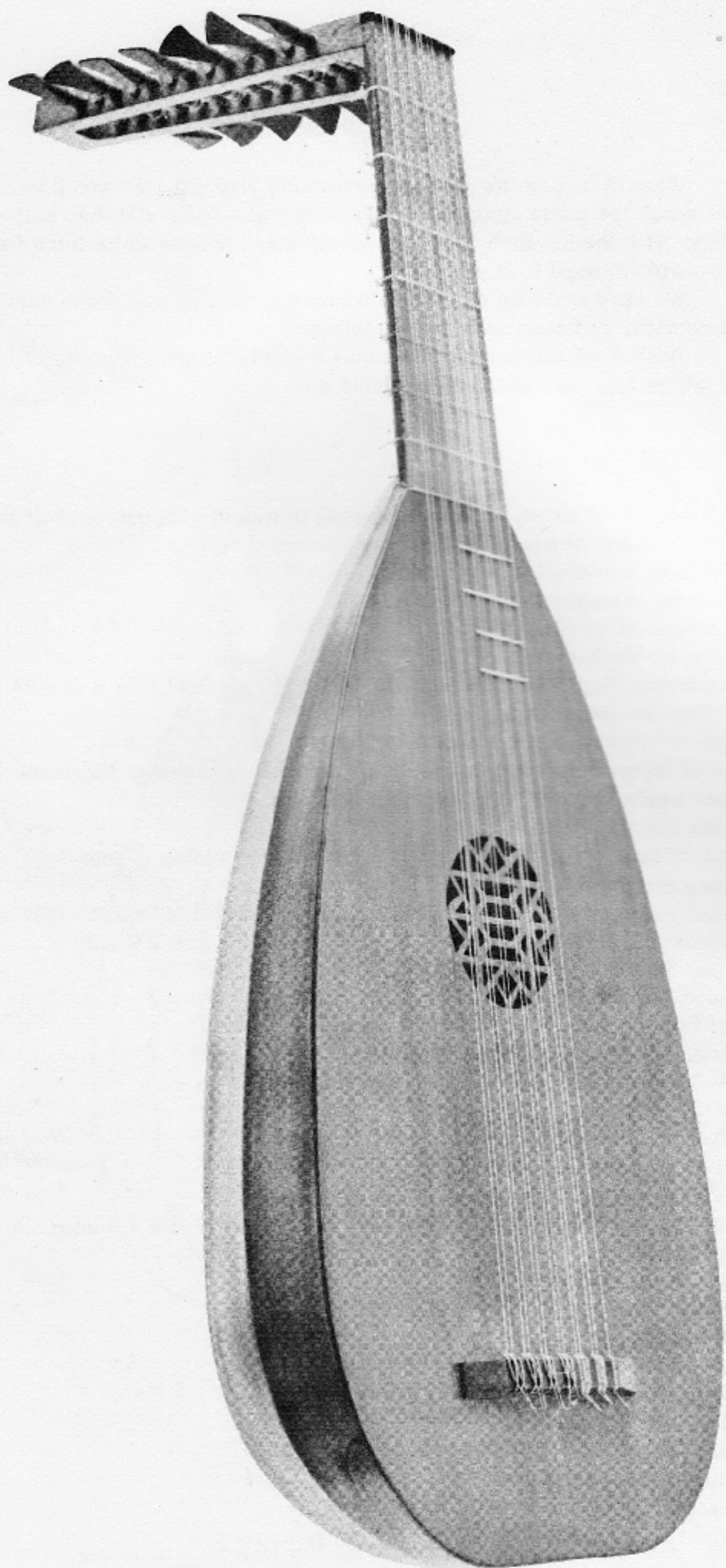

Introduction

Perhaps the first thing you would like to know a little about, is the history of the lute you are about to build. The lute kit is based on an instrument designed by Ian Harwood and John Isaacs, who in turn have used the work of the Italian masters in Bologna as their reference. These makers include Hans Frei and Laux Maler, who were working from about 1550 - 1650. Quite a number of instruments have survived from this period, and they are used as a basis for nearly all modern building.

The lute you will make has seven 'courses'. This means theoretically seven pairs of strings, but the 1st or top course is nearly always a single string. Thus you have 13 strings (I hope you are not superstitious). The pairs of strings are tuned in unison and to the following notes:- g', d'd', aa, ff, cc, GG, DD. The g' is the one above middle c on a keyboard instrument.

The seven course lute was developed in about 1590, and it is suitable for all English and European music of that period. Further courses were added later, but this music can easily be adapted to your instrument. For the beginner, seven courses are much more manageable and you will find that the tutors cater for this type of instrument. Tutors are listed at the end of this section.

The lute kit that we have produced is designed to be built by anyone, including those without any woodworking skill. If you were to make a lute from scratch, you would first need to build a mould or form over which to make the back. This is a most difficult task, and requires a great deal of accuracy. It is for this reason that we have supplied you with a pre-formed mould made in synthetic material. The synthetic mould also has the added advantage that you can tap wooden wedges into it to provide clamping.

As tools are expensive, we have tried to make the method of construction simple, using, as far as possible, tools that you would be likely to have around the house. Any special tools required are listed at the end of the introduction. We have taken care to pre-shape all the parts that require great accuracy, and we have included spare parts where we have felt it necessary.

The basic method of construction of this instrument follows the traditional methods, which remained virtually unchanged throughout the history of the lute. In particular, the barring on the underside of the soundboard remains faithful to the originals, giving the authentic tonal qualities. The angled pegbox, wooden pegs and tied frets also conform to tradition. We have chosen traditional woods for the parts, and have kept to the authentic measurements, in order to provide a light resonant lute with the right tonal qualities for the music.

Tools required for Construction

Hammer, screwdriver, chisel, medium sand paper, fine sand paper, sanding block, cutting knife (provided), pliers, scissors, triangular file, two 2" (50.8 mm) clamps, sellotape, fine saw, synthetic resin glue, white glue (P.V.A.), contact adhesive, cutting board.

Carcamite
or
aerolite

Evostick Resin W

Suggested Tutors

Method for the Renaissance Lute - by Stanley Buetens.

An Introduction to Lute Playing - by Diana Poulton

School of Musick - by Thomas Robinson

A Varietie of Lute Lessons - by John Dowland

Now you are ready to start work. You will find it a great help if you read the instructions right through several times before you start. Also study the drawings relevant to each stage before doing the work. Good luck, and please let us know how you get on with it.

ASSEMBLY OF THE LUTE KIT

1. Initial Preparation

Before you start assembling your kit, you should have in front of you, a baseboard fitted with a mould, a neck block, and an end block.

Commencing at the front end of the baseboard, hammer $3/4$ " (19 mm) pins at 3" (76 mm) intervals along the side edges, and one in the centre of the front edge (Fig. 5, Page 9).

Take the two neck block clamps (Fig. 1) and sand off the sharp edges, before putting in position over the neck block as shown. Mark on the clamps the approximate central position of each rib. Remove the clamps and hammer $3/4$ " (19 mm) pins into the positions marked, leaving about $3/8$ " (9.5 mm) protruding. Replace clamps on to neck block and put baseboard aside until required again.

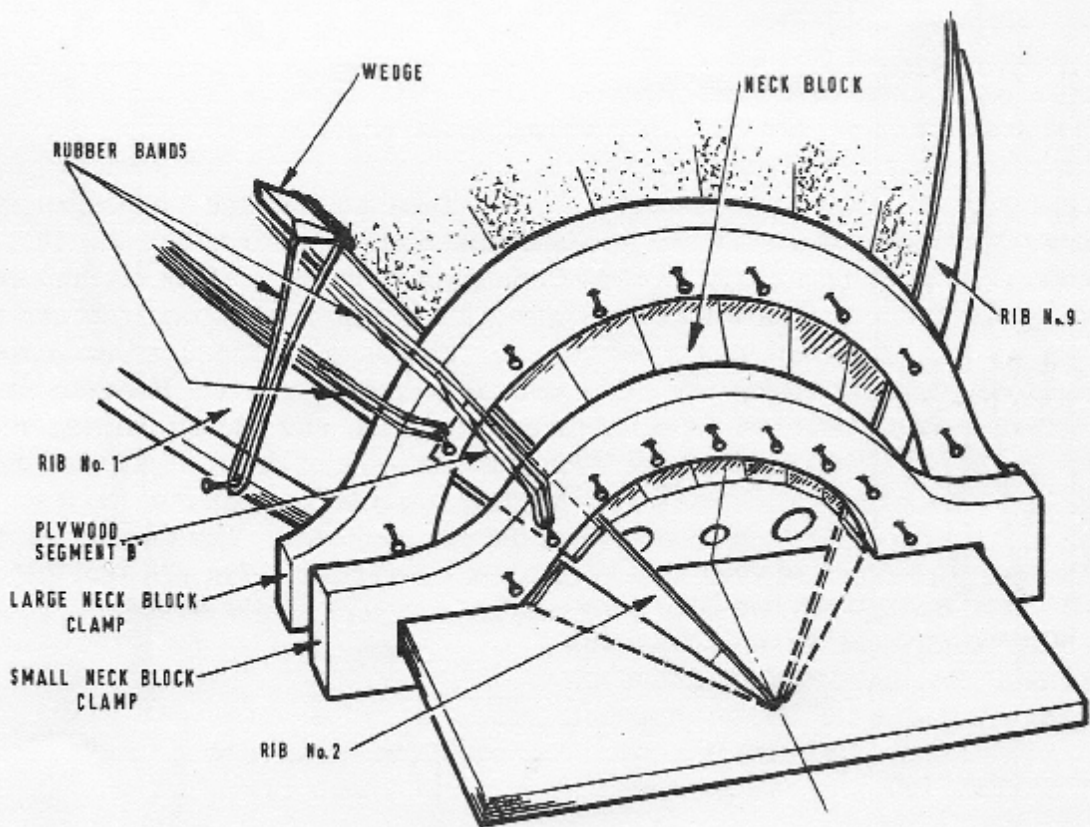

FIG. 1.

2. Cutting the Ribs.

Lay out the ribs in numerical order with the numbers upwards. You will find you have three spare ones so take one of these to experiment with first. Now you will need a piece of board (plywood or solid timber) larger than the ribs, to cut on.

Place the rib on the cutting board, and then position the rib template centrally on the rib (Fig. 2). Hammer two 5/8" (16 mm) pins through the template and rib into the cutting board, 3/4" (19 mm) from each tip, just enough to hold it rigid. Now carefully cut out the rib with the knife provided. The best method of cutting is to start at the widest part of the template and cut towards the points keeping the knife upright to avoid straying from the shape of the template. It is better to draw the knife round the template 5 or 6 times than to try cutting the rib in one go.

Now you should feel confident enough to cut rib No. 1, remembering that the numbered side should face upwards.

Cut off the neck end of the rib 1/2" (12.7 mm) from the tip to make fitting easier later.

3. Sanding the edges

Turn the rib over (un-numbered side up) and sand both edges to an angle of 10° . Commence at the neck block end and work to within 1 1/2" (38 mm) of the front end (Fig. 3).

This is much simpler than it sounds, and can be judged by eye. Hold the rib over the edge of a table, and place a sanding block against the edge of the rib. Tilt the block slightly towards the centre of the upper surface of the rib, and sand. Try this out on the spare rib you cut earlier. You will find that it only needs a few very gentle strokes.



SECTIONAL VIEW OF THE RIB

FIG. 3.

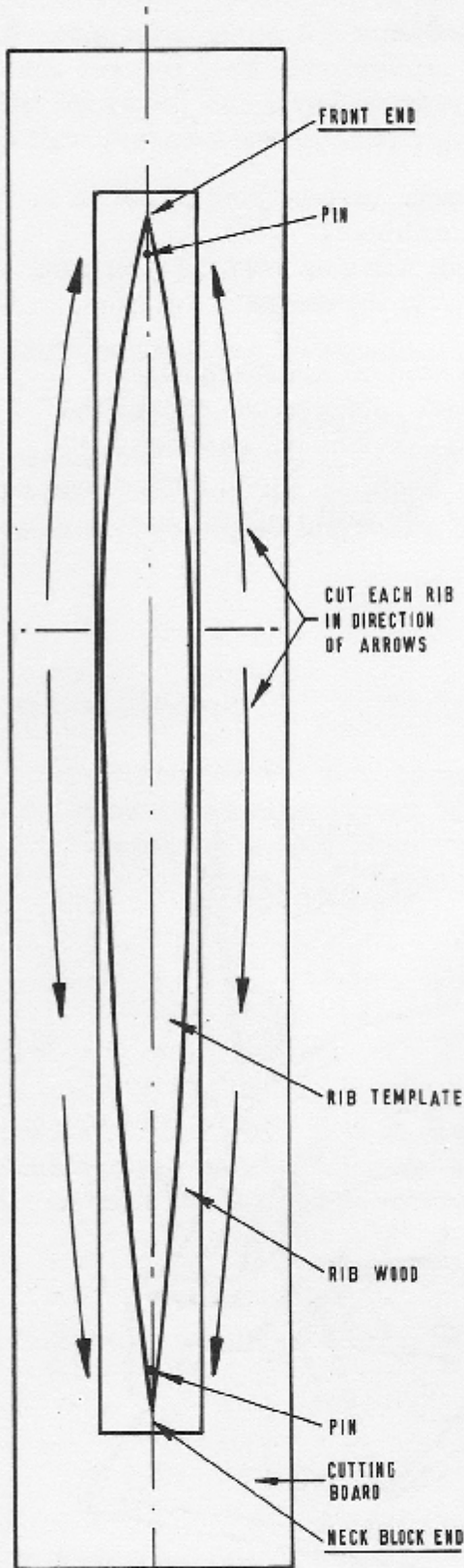
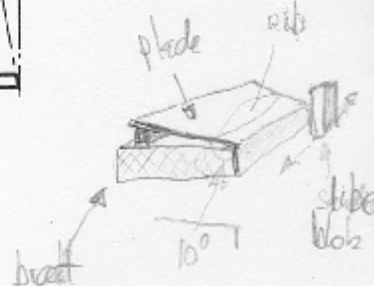
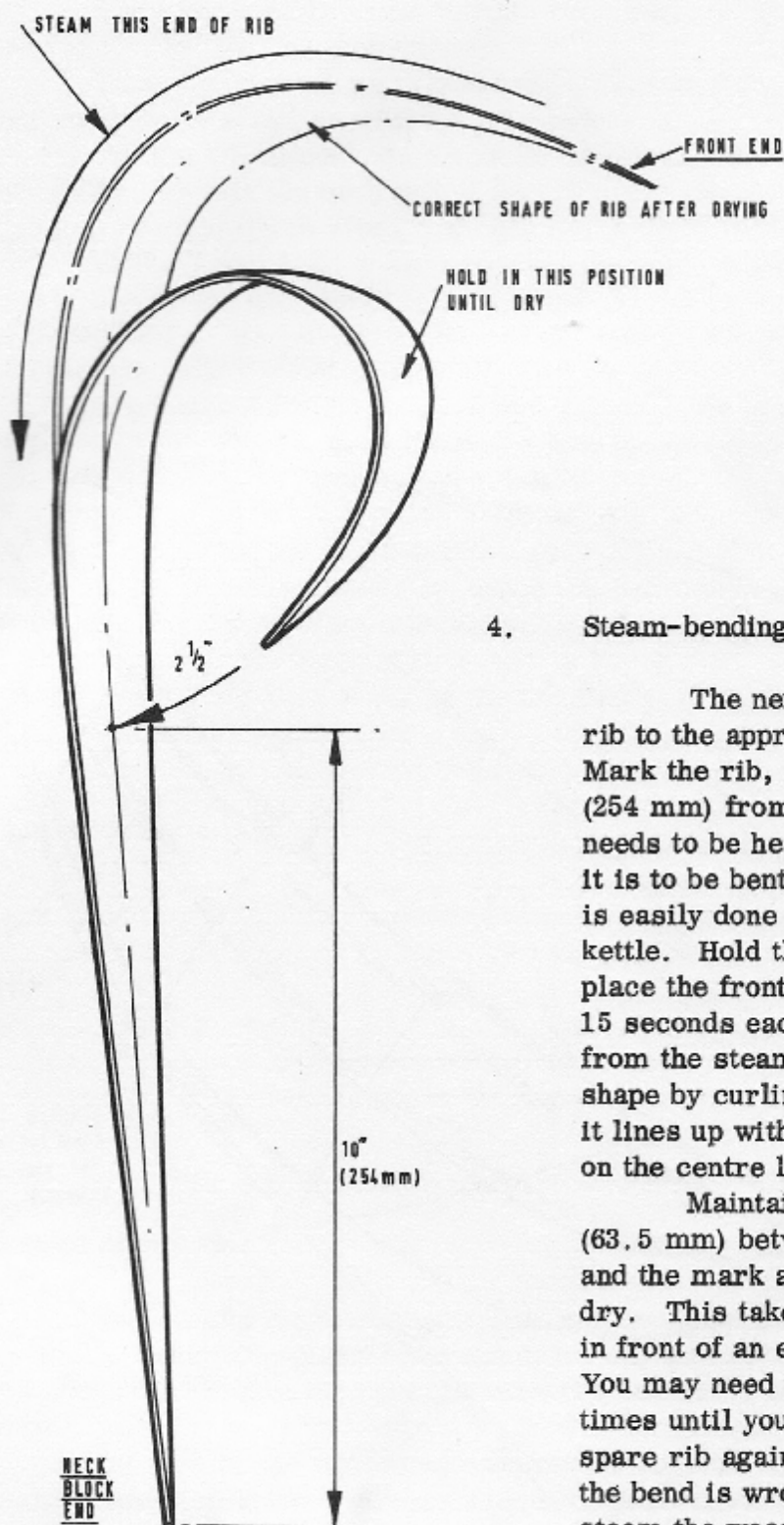

FIG. 2.





4. Steam-bending the Rib

The next operation is to bend the rib to the approximate shape of the mould. Mark the rib, on un-numbered side, 10" (254 mm) from the neck end. Now the rib needs to be heated and moistened where it is to be bent, to make it pliable. This is easily done with steam from a boiling kettle. Hold the rib by the neck end, and place the front end in the steam for about 15 seconds each side. Remove the rib from the steam, and bend to the required shape by curling the front end over until it lines up with the mark you have made on the centre line of the rib.

Maintain a gap of about 2 1/2" (63.5 mm) between the front end point and the mark as shown in Fig. 4. until dry. This takes about a minute if held in front of an electric fire. You may need to try this process a few times until you get the feel of it. Use the spare rib again to experiment with. If the bend is wrong first time, just re-steam the wood, and adjust the shape.

FIG. 4.

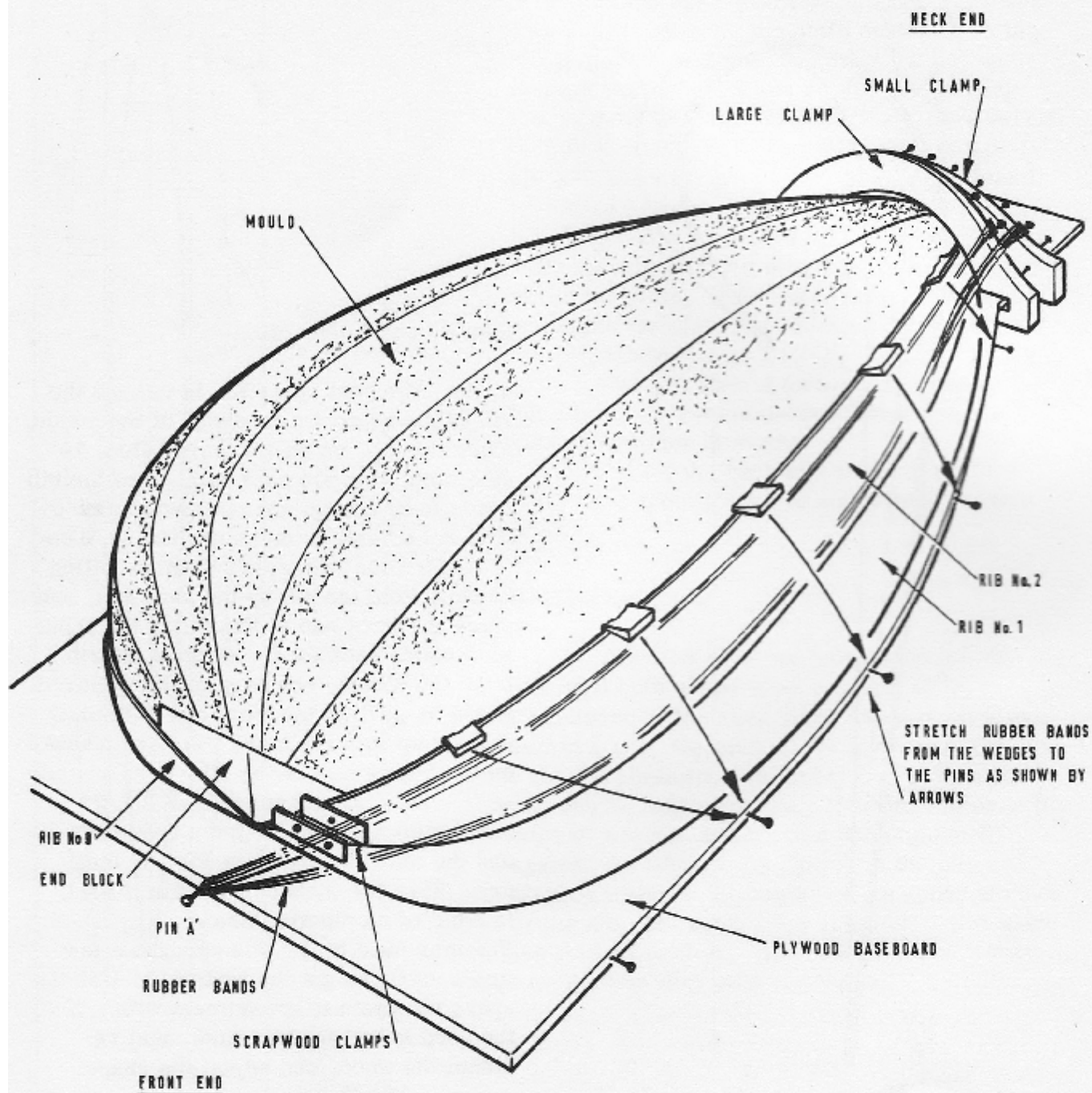

FIG. 5.

VIEW OF FIRST STAGES OF ASSEMBLY

5. Fitting Rib No. 1

Now clamp your baseboard to a table or bench, with the neck block clamps overhanging the edge.

Cut 2" (50 mm) from your length of laminated scrapwood for a clamp.

Tap a pin 5/8" (16 mm) into it centrally, 1/2" (13 mm) from one end and keep handy for use in a moment.

Take the bent rib No. 1 and assemble it as follows before glueing, so that you become familiar with the procedure.

Put the rib against the mould in the No. 1 position, adjacent to the baseboard (Fig. 6), with the neck end of the rib under the two clamps. This procedure may be reversed if you wish, e.g. Rib No. 1 fitted in No. 9 position, etc.

At the Front End, make sure that the point of the rib is in line with the centre line on the end block. Check round the rib to the Neck Block End, that it is fitting well on the baseboard while tight against the mould. If there is any discrepancy, sand the edge carefully, keeping to the 10° angle.

When it looks right, tap the pin in your piece of scrapwood, through the rib (about 3/4" 19 mm from the point) into the end block (Fig. 6). The pin hole will be covered by the capping strip later.

Secure the rib in position by stretching two large rubber bands from "Pin A", over the rib to the corresponding pins in the two neck block clamps (Fig. 1). Tuck in the plywood segment "B" under the neck block clamps, to hold the rib tightly against the neck block as shown.

When you are happy that the rib is fitting well, mark on the portion to be glued. This is the area covering the end block. (Fig. 6).

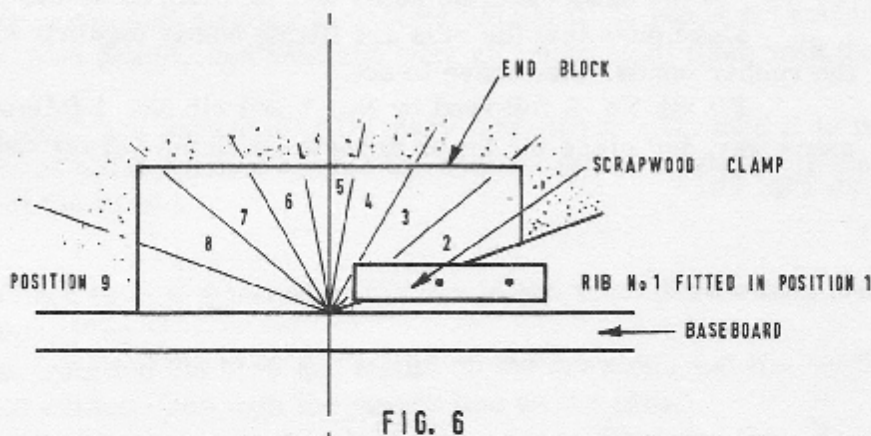

6. Glueing on Rib No. 1.

Remove the rib from the mould, and make sure that everything that you need is to hand. Cover the front end of the rib with resin glue up to the mark you made, and secure it in position with the use of the pin and scrapwood as before.

Put glue on the appropriate section of the neck block. Secure the rib in position over the mould, with the use of the neck block clamps, bands and plywood segment. Tap two or three wedges into the mould, along the upper edge of the rib to hold it against the baseboard. See Fig. 5 for example.

If the neck block clamps move slightly, bands stretched round the No. 9 position on the mould will make them secure.

Leave until glue is set.

Repeat this process for rib No. 9, which takes its position on the opposite side of the mould.

When set, remove the bands and clamps and any surplus glue that will prevent the good fit of the adjacent rib. Trim the neck end of the rib flush with the back of the neck block.

7. Fitting Rib No. 2 followed by No. 8

Cut the rib, sand the edges to 10° and bend as for ribs 1 and 9.

Replace neck block clamps onto the mould and a scrapwood clamp into rib No. 1 to tuck rib No. 2 under (Fig. 6a).

Commence by tucking the front end of rib under the scrapwood clamp, next to rib No. 1 (Fig. 6a), and the neck end under the neck block clamps. Secure with rubber bands and check that it fits well to No. 1 all along its length, whilst fitting tightly to the mould. If the rib is a bit tight anywhere, causing a gap somewhere else, sand the edges until an accurate fit is achieved, keeping the 10° angle.

Tap 5 or 6 wedges into the mould, along the top edge of the rib to correspond with the pins along the edge of the baseboard. Stretch rubber bands from the wedges to the pins, diagonally if necessary, to clamp ribs 1 and 2 tightly together.

Mark on the rib the area to be glued at the Front End, as before. Remove the rib from the mould.

Have ready a second scrapwood clamp and the plywood segment "B".

Apply glue to the portion of the rib that fits onto the end block, along the edge that fits against rib No. 1 and to the appropriate section of the neck block.

Place in position on mould and secure at the Front End with a second pin through the scrapwood clamp (Fig. 6a). Secure at the neck block end as before and place plywood segment "B" in position.

Take the second scrapwood clamp and pin through rib No. 2 into the end block just above the first clamp. (Fig. 6a). If the pins are kept within an inch (25 mm) of the baseboard, the holes will be covered by the capping strip.

Make sure that the ribs are fitting neatly together after you have put on the rubber bands, then leave to set.

Fit rib No. 3 followed by No. 7, and rib No. 4 followed by No. 6 in the same way, but place the lower scrapwood clamp across the fitted ribs as shown in Fig. 6b.

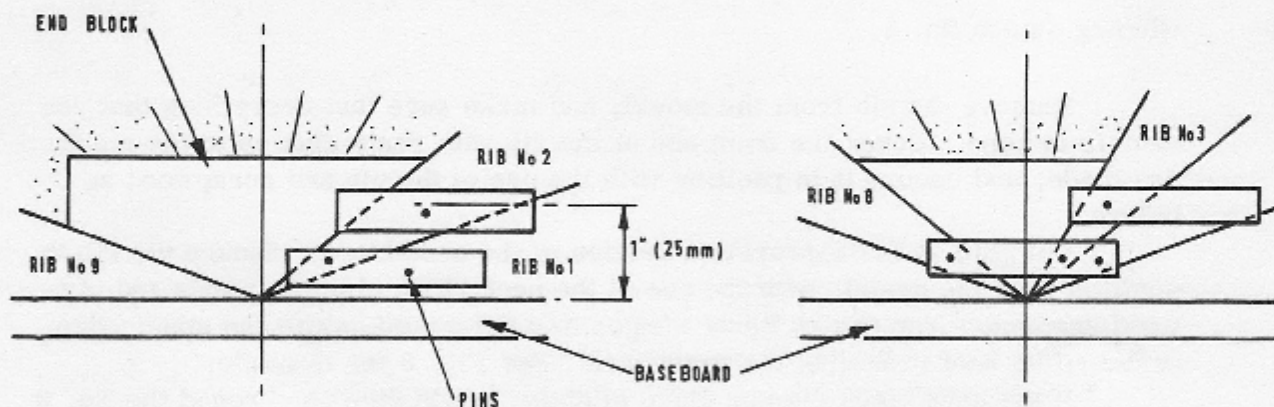

FIG. 6a

FIG. 6b

8. Fitting the Last and Central Rib, No. 5.

First check that the space for rib No. 5 is not larger than the rib template, as a slight accumulated error could have occurred throughout the fitting of the previous ribs. If it is larger, you can allow for this when cutting the rib.

When you have cut, sanded and bent the rib, fit the first 4" (100 mm) of the Front End point and push down behind the scrapwood clamp. Place the neck end under the neck block clamps and secure with rubber bands to see how well it fits along its length.

If the rib is too large anywhere, draw round the part that is overlapping onto the adjacent rib. Then you will know how much to sand off.

When you have achieved a good fit, apply glue to the rib in the appropriate places as for previous ribs. Secure with as many rubber bands as you need until the ribs fit neatly together. You will find it necessary to fix bands along the three central ribs and over the back from side to side.

Leave to set.

9. Cleaning up the Back

When the last rib has been put on and the glue is set you can remove the clamps etc., and sand most of the back while it is still on the baseboard.

Use a medium grade sand paper with a sanding block to remove any saw marks and surplus glue. Keep the sanding block flat on each rib.

Now you can remove the back, complete with mould, from the baseboard by extracting the screws located under the baseboard. Sand any parts you could not get to before, then finish the back all over with fine sand paper.

Have ready some soft padding to protect the back, as you must now turn it over, complete with mould, and sand the edge all round until flush with the mould.

If the end block has sprung slightly away from the mould, hold it in position tightly, to ensure a flat surface to glue the soundboard to. Keep your sanding block on the flat of the mould.

NOTE:

While the back is still attached to the mould you must draw round it onto the soundboard plan, (Plan 1).

To do this, position the back and mould on the drawing, and line up the end and neck block centre lines with the centre line on the plan.

Make sure that the neck block is in the correct position and then, holding the end block in tightly to the mould, draw round the back. This will be used when fitting the bars.

You can now remove the mould from the back by inserting a screwdriver into the mould at the neck end and gently prising it out.

Now the back is ready to be taped inside.

10. Taping the Inside of the Back

Tape is now glued along the joints on the inside of the back to provide added strength. Cut the tape provided, into lengths to fit between the two blocks. Use a small brush to apply resin glue along the joints, lay the tape on the glue, and press down firmly, Fig. 7.

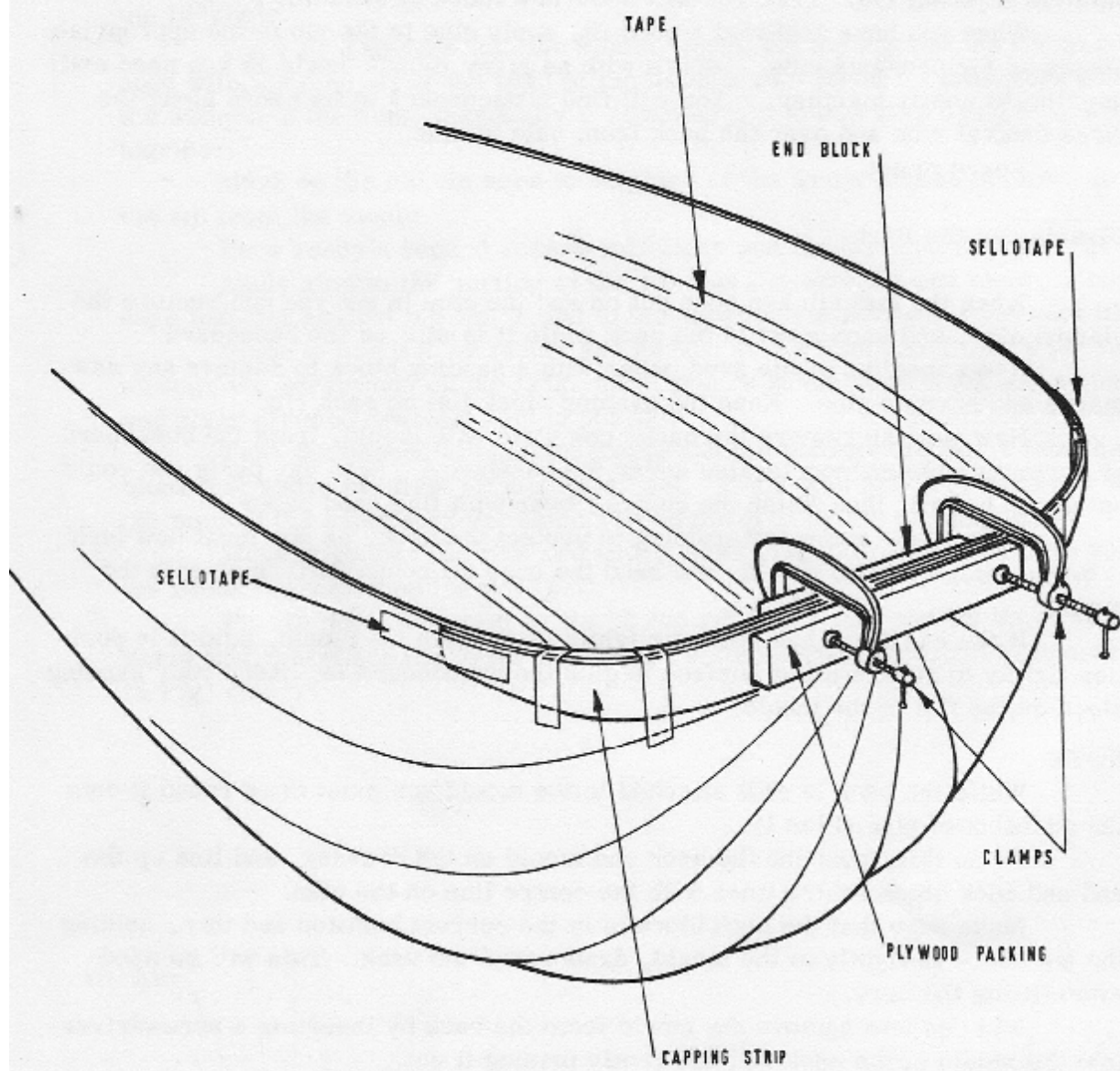

FIG. 7

VIEW OF CAPPING STRIP CLAMPING

11. Fitting the Capping Strip

Sand the outside face and the bottom edge of the capping strip and mark on the centre line. Steam bend it to the shape of the back. Cover the inside face of the strip with resin glue and then hold it firmly to the back. Keeping the strip slightly above the edge of the back, secure it between the end block and a packing block, with the use of two small clamps. Sellotape stretched tightly over the capping strip and attached to the inside of the back will secure the ends (Fig. 7). If you have more small clamps, use these too. When the glue is set, sand the strip until it is flush with the edge of the back. Re-mark the centre line on the outside of the capping strip accurately to match the one on the end block.

12. The Soundboard or Belly

First sand the soundboard wood on both sides with medium grade paper, evenly all over. Choose the best side, and sand with fine sand paper. This will be called the face. From now on, take care to keep the soundboard on a clean smooth surface as it marks very easily.

With the back of the soundboard uppermost, draw on the centre line. The centre line is where the two pieces of wood are joined.

13. Marking out the Soundboard

The next stage is to mark out the bridge, the rose, and the bar positions on the back of the soundboard. Cut the plan of the soundboard off from your drawings, and place it on top of the soundboard wood, centre line to centre line. Secure it in place with sellotape. Use a needle or pin to prick through the plan at the points marked with a dot. These marks give the positioning of the bars, the neck block and the bridge. The two dots outside the end block will mark the position to which the outside edge of the capping strip will be lined up when glueing the back to the soundboard. Remove the plan, and draw in the lines between the dots, so that the soundboard is marked out exactly like the plan. Number the bars as shown.

14. The Rose

Place the point of a pair of compasses in the centre of bar 4, and draw a circle of radius $1\frac{1}{2}$ " (38 mm). Glue your choice of rose design to the back of the soundboard, centre line to centre line, using a white glue (PVA). Allow glue time to set. You can then see how bars 4, v, and w, will cross the rose design No.1, under the soundboard. Using the cutting knife provided, cut out the shaded areas. Cut from the back of the soundboard, and only work on the front afterwards, to clean up the lines.

Leave the paper pattern of the rose glued to the soundboard, as this provides extra strength.

Measure the radius of the outside circle of the rose design.

With a pair of dividers, scribe a circle of this radius onto the face of the soundboard to finish the rose.

Sand with fine sand paper.

Note

If you feel unsure about cutting the rose design, cut off a small piece of excess soundboard wood to experiment with first.

15. Putting on the Bridge

You already have the bridge position marked on the back of the soundboard, and now it must be transferred to the face. Extend the lines marked for the bridge on the back, out to the edges of the wood, and mark them on the face. Place a ruler across the face to these marks, and then pencil light lines $2\frac{1}{2}$ " long (63.5 mm) each side of the centre line of the soundboard.

Sand the bridge to finish required.

Mark a centre line on the bridge. Tap two $\frac{5}{8}$ " (16 mm) pins about $\frac{1}{8}$ " (3.2 mm) into the under side of the bridge, cut off the heads of the pins so that a soundboard thickness protrudes.

Hold the bridge, bevelled edge towards the end block, in position over the soundboard and when accurately placed, press down to get an impression of the pins on the soundboard. The holes left in the soundboard will act as location points when glueing the bridge into position.

Find the piece of plywood $5\frac{1}{8}$ " x $\frac{3}{4}$ " x $\frac{3}{8}$ " (130 x 19 x 9.5 mm) provided in your kit. Tap two $\frac{5}{8}$ " (16 mm) pins into it, and keep ready to use in a moment.

Cover the underside of the bridge with resin glue, place it in position on the soundboard, and press down firmly. Turn the soundboard over, place the plywood over the bridge outline, and hammer the pins through the plywood, and the soundboard, into the bridge. (Fig. 8). Clean off any surplus glue and leave it to dry. When it is dry, you can remove the plywood, complete with pins, quite easily.

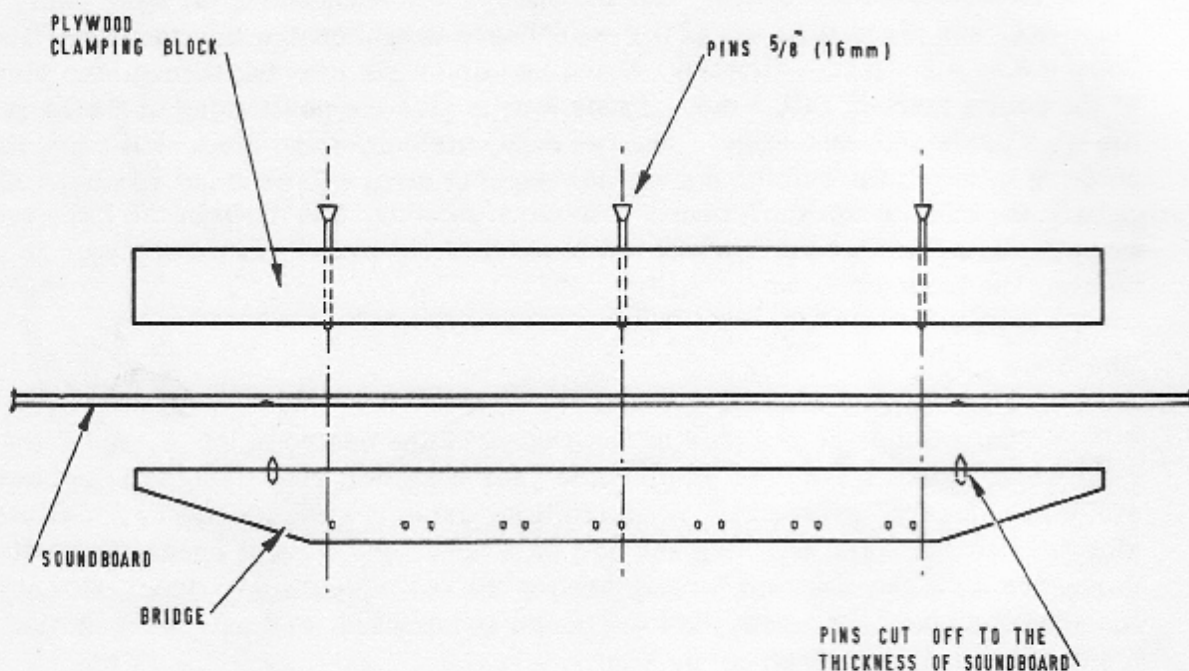

FIG. 8

16. The Bars

Bars z, x, y, v and w	$\frac{1}{4}$ " x $\frac{1}{8}$ " (6.4 x 3.2 mm)
Bars a, b, 3, 4, 6 and 7	$\frac{1}{2}$ " x $\frac{1}{8}$ " (12.7 x 3.2 mm)
Bar 5	1" x $\frac{1}{4}$ " (25.4 x 6.4 mm)

17. Bending the Bass Bar

Cut one piece of $\frac{1}{4}$ " x $\frac{1}{8}$ " (6.4 x 3.2 mm) barwood about 8" (203 mm) long, and bend it to the shape shown on Plan 1. This can be bent in the same way as you bent the ribs, but it will take a little longer in the steam, say 30 - 40 seconds, as the wood is thicker.

18. The Length of Bars

The next process is to determine the length of each bar. The printed line on the plan represents the outline of the mould and the pencilled line you made represents the outline of the back. If the distance between these lines is more than $1/16''$ (1.6 mm), (most unlikely), the difference will have to be added to the bar length when marking out.

19. Marking and Cutting the Bars

Place the barwood on its appropriate bar line on Plan 1, and mark off the length on either side of each bar, and at each end. This will give angle 1, as shown in Fig. 9. and will ensure that the bar is parallel to the side of the lute. Do not forget to increase the length of the bar at this stage if necessary. Now join up the marks across the bottom of the bar.

Next you have to consider angle 2, (Fig. 9.). This angle forms the joint between the bar and the inside surface of the back. The angle is achieved with the use of the angle marker supplied (Fig. 9). Place the marker against the bottom of the bar, lining it up with the mark already made on the bottom, see Fig. 9. Draw the line, shown by the marker, on the side of the bar. Slide the marker along the bottom of the bar, and mark the other end. Turn the bar over, and repeat this on the other side. Join up the marks on the top of the bar. Mark also the bent end of the bass bar, and one end of treble bar y, in the same way. When all the bars are marked out, cut them to length and check them against the plan. Mark a centre line on each one, and number it according to the plan. Thin the bars 4, v and w in the middle if necessary to fit the rose design. Sand the sides of the bars and they will be ready to glue on.

If you have chosen rose design No. 2, bars 4, v and w should be coloured black with stain or ink to make them less conspicuous.

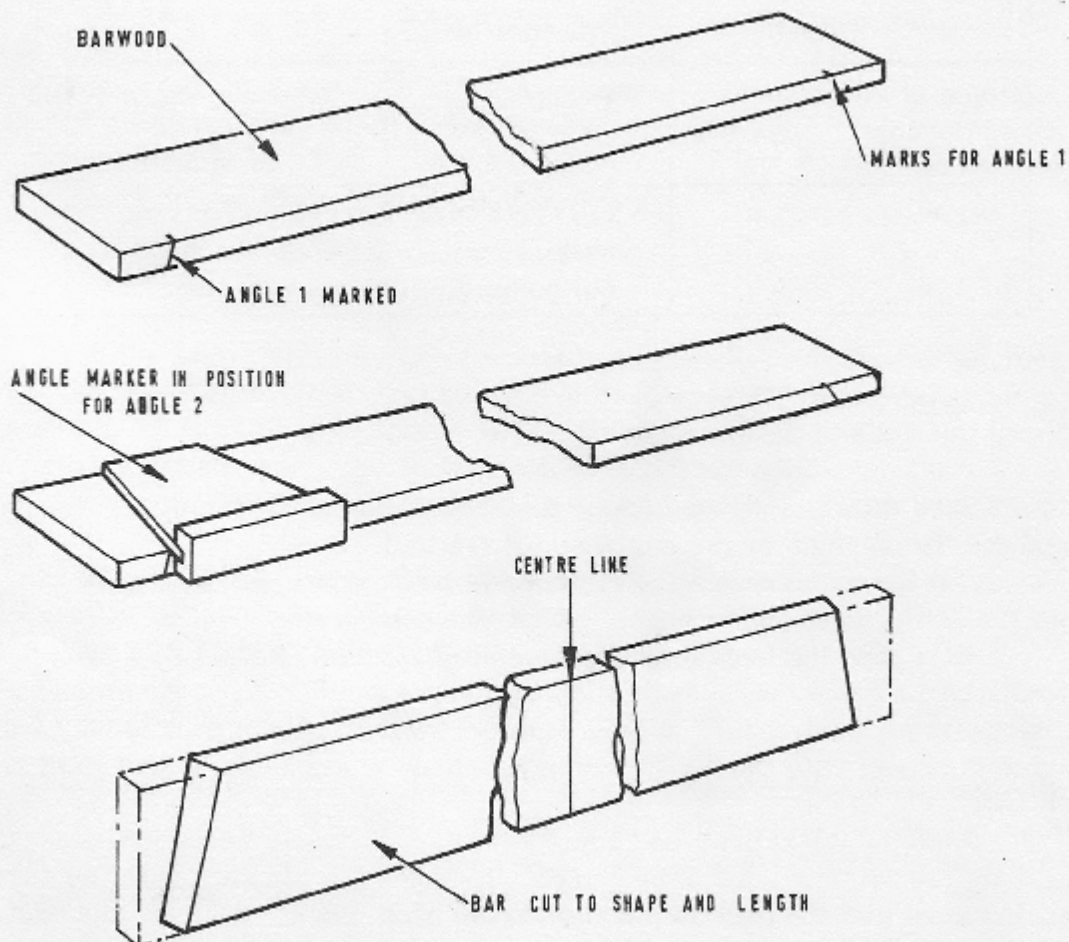

FIG. 9

20. Glueing on the Bars

Place the baseboard on a flat surface and lay the soundboard on it, with the bridge through the hole provided. The first bars to be fitted are the small ones, i. e. bass bar z, treble bars x and y, and bars v and w. Apply glue to the bottom of each bar and locate it between the appropriate lines which you made on the soundboard. Line it up also with the centre line. When you have fitted the small bars, place weights on top of them (i. e. heavy books) to hold firmly down onto the soundboard.

When these are dry, repeat this for bars a, b, 3, 4, 6 and 7. The large bar, 5, is the last to be glued, and can be held with two small clamps over the bar, and under the baseboard, as weights may cause it to overbalance.

When all the bars are glued and dry, they must be shaped and cut down at the edges as shown in Fig. 10. This can be done with the knife provided.

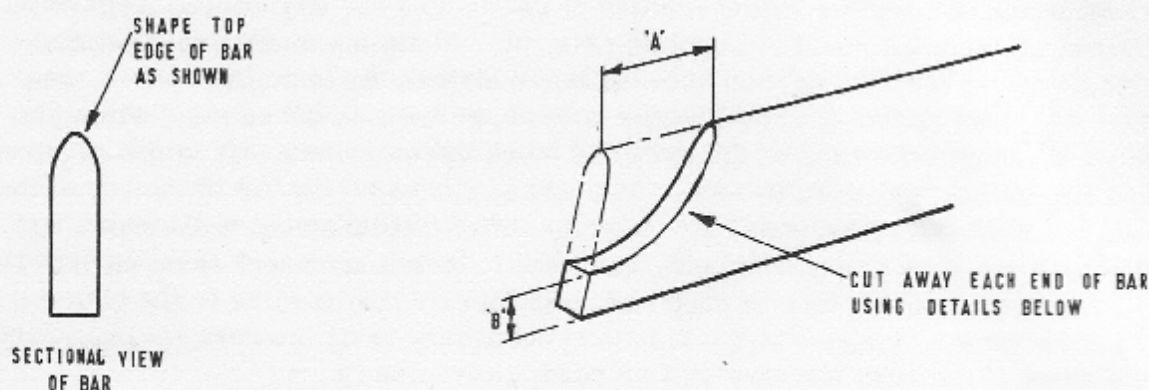

FIG. 10.

Bars	Length 'A'	Height 'B'
5	1" (25 mm)	1/4" (6.4 mm)
a, b, 3, 4, 6 and 7	3/4" (19 mm)	1/4" (6.4 mm)
v, w, x, y and z	1/2" (13 mm) shaped only on the ends which do not come into contact with the ribs.	1/16" (1.6 mm)

21. Fitting the Neck to the Back

Sand the rounded surface of the neck to the finish required. Do not sand the flat surface or the surfaces to be fitted.

Cut the piece of dowel provided, in half. Put a small amount of glue into the dowel holes in the neck, and tap the dowels in.

Now push the neck onto the neck block, **WITHOUT GLUE**. The dowels should not be loose, but should slide into place easily. Sand the dowels a little if necessary. Push the 2 1/4" (57 mm) screw through the neck block, from inside the back, into the neck. Screw in, making sure that a tight joint is formed.

Remove the screw, and apply glue into the dowel holes in the neck block, and onto the two surfaces to be joined. Reassemble the neck with the screw, making sure that the neck is parallel to the neck block. Remove any excess glue, and leave to set.

22. Cutting and Fitting the Soundboard to the Back

Lay the soundboard on the baseboard with the bars upwards, and place the back of the lute on top, over the bars. Position the neck block correctly, and line up the end block with the centre line on the soundboard. Two or three rubber bands stretched over the back and attached to the pins in the baseboard will hold it steady. Push on the capping strip until it is in the position you marked on the soundboard. Check that the bars are touching the inside of the ribs by applying finger pressure on the outside, and push the back in as necessary.

Draw a line round the back about 1/8" (3.2 mm) from its edge. Remove the bands, and the back from the soundboard, and cut off surplus soundboard wood to this line. Also cut off the soundboard accurately along line N-N to ensure a neat joint with the fingerboard. (Plan 1). Replace the back on the soundboard, and stretch bands across the back until a good joint is achieved. This should be sufficient, but if you still have trouble, a few wedges pushed gently between the soundboard and the baseboard, will help. Check that the soundboard lines up with the end of the neck. When you are satisfied that all the joints fit well, it is ready for glueing. Apply resin glue to the ends of the bars, the edge of the back, the neck block and the end block. Position the back carefully and correctly on the soundboard as before, and secure once again with bands. Push the sides of the back in until all the bars are touching the inside of the back. Leave until the glue is dry, and then remove the bands.

To flush down the soundboard to the back, hold the back firmly down on the baseboard, and trim with your cutting knife. Be sure to cut commencing at the widest part of the back, and work from this point towards each end as you did when cutting the ribs. Finish the edges with sand paper. Where the capping strip ends, allow the soundboard to form a curve, not a step.

23. Fitting the Pegbox

Sand paper all the surfaces of the pegbox, except those which adjoin the neck.

Apply glue to the rebate in the neck and place the pegbox in position. The holes are ready drilled, so all you have to do is form a good tight joint with the 5/8" (16 mm) screws.

Clean off the surplus glue and leave to set.

24. The Fingerboard

Cut the fingerboard to approximate size and shape of the flat surface of the neck. Allow 1/16" (1.6 mm) overlap at each side and about the same at the fretnut end. A good fit is essential at the soundboard end.

Secure the fingerboard to the neck with contact adhesive.

Trim the sides and the fretnut end of the fingerboard with your knife or chisel.

Using a sanding block with medium grade paper, rub down the fingerboard until it is flush with the soundboard.

Now round off the sharp edges as shown in Fig. 11.

* 21. Before fitting the Neck to the Back.

It is most important to make sure you have trimmed the ribs flush with the back of the neck block before fitting the neck. Failure to do this will result in incorrect alignment with the soundboard. You must aim to get the soundboard and fingerboard perfectly level.

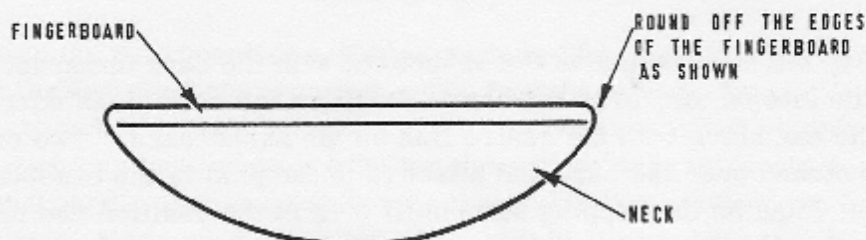

FIG. 11.

25. The Fretnut

Check that the fretnut fits the rebate well. It should be flush with the pegbox and protrude $1/16''$ (1.6 mm) above the fingerboard.

Mark out the string positions on the fretnut using Plan 2, and then make light grooves in the fretnut with a file, Fig. 12.

Apply resin glue to the rebate in the neck, and clamp the fretnut in position with two small clamps. Secure the clamps over the fretnut and inside the end of the pegbox. Remove any excess glue and leave to dry.

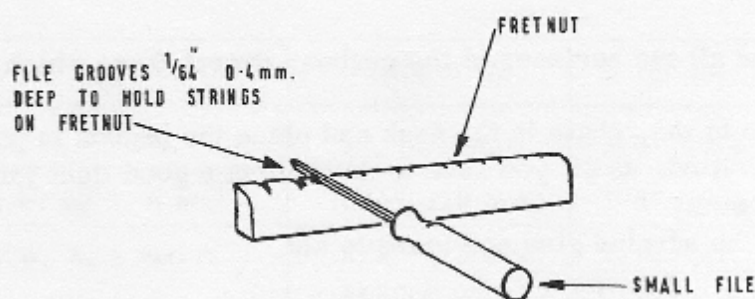

FIG. 12

26. The Pegs

Sand the finger grips. Push the pegs into the holes in the pegbox until they are tight. Select the peg with the shortest distance between its shoulder and the pegbox. Leave this peg in position and reduce the diameter of the other pegs by sanding, until the distance from the shoulder to the pegbox is the same on all of them. (Plan 3). When they are all fitting correctly make sure that you keep them in order, or you will find yourself with a lot of refitting.

The right length of each peg is $1/16''$ (1.6 mm) beyond the pegbox. Mark this position and remove the pegs from the box. Saw off and round the ends to finish as shown in Plan 3.

27. Marking out the Fret Positions

Cut the plan of the fret positioning (Plan 2) from your sheet of scale drawings. The measurements should be correct, but check with a rule, as there may have been a little expansion in the printing of the drawing. If it is correct, tape it onto the fingerboard and mark each fret position onto both edges of the fingerboard. Frets 9 - 12 will have to be pricked through onto the soundboard. Do NOT draw lines right across the fingerboard as this will spoil the appearance of your finished lute.

If the plan is not quite correct, use the measurements given below, which represent the distance of each fret from the lower edge of the fretnut.

Fret 1.	1.35"	(34.29 mm)	Fret 7.	7.98"	(202.69 mm)
Fret 2.	2.62"	(66.55 mm)	Fret 8.	8.88"	(225.55 mm)
Fret 3.	3.82"	(97.03 mm)	Fret 9.	9.74"	(247.4 mm)
Fret 4.	4.95"	(125.73 mm)	Fret 10.	10.53"	(267.46 mm)
Fret 5.	6.00"	(152.4 mm)	Fret 11.	11.28"	(286.51 mm)
Fret 6.	7.03"	(178.56 mm)	Fret 12.	12.00"	(304.8 mm)

Frets 1 - 8 are nylon, with fret 8 coinciding with the joint between the soundboard and the neck. DO NOT FIT THESE FRETS YET.

Frets 9 - 12 are wooden frets on the soundboard, so prepare these next. Cut them from some spare rib wood.

They are all $1/16$ " (1.6 mm) thick x $1/32$ " (0.8 mm) high, but frets 9 and 10 are $1\ 5/8$ " (41.3 mm) long, and 11 and 12 are $1\ 1/8$ " (28.6 mm) long.

Draw lines across, between the points which you pricked through for frets 9 - 12. The frets line up with the point where the edge of the fingerboard joins the soundboard. They do not follow the line of the edge of the fingerboard, but are at right angles to line N - N (See Plan 2).

Glue these frets in position with white glue, e. g. PVA. Light clamping can be applied by sticking sellotape over the ends.

28. The Final Finishing of the Wood

With fine sand paper, work over the lute to remove any blemishes that may have occurred during construction. When this is completed, you can apply a varnish to the wood. The easiest varnish to use is probably Polyurethane, which can be obtained either clear or coloured as preferred. Use this thinned with white spirit. It can be put on with a brush or piece of cloth and should be applied to the back, neck, fingerboard, pegbox, bridge and finger grips of pegs. Put on several coats, but sand well between each coat.

Traditionally, the soundboard was not varnished, but it sometimes had a thin coating of egg-white. As the cedar used for the soundboard is very soft, you may feel that some protection is necessary. If so, a couple of coats of the thinned varnish will have no adverse effect on the tone of the instrument.

29. Fitting the Nylon Frets

Lay your lute face down on a flat, soft surface, e. g. carpet or rug, with the bass edge towards you.

Each fret should be tied about three positions higher up than its final placing and then lowered into position. This is to ensure that the fret is really tight. Be sure that you set each fret accurately on the marks, as this determines the scale.

Do not cut the nylon into lengths but slip it under the neck with the long length towards you.

Bring the short end over the rounded back of the neck, and tie a figure of eight knot. (Fig. 13) Pull the nylon up tight by holding the long end and giving it a quick jerk.

To lock the knot, make a loop with the long end and thread the short end through it. Now pull on both ends simultaneously until the knot is absolutely tight. Use pliers to hold the short end.

Lower into correct position and cut off the ends about $3/16$ " (4.8 mm) from the knot. Touch the nylon ends with a lighted match to finish.

Try not to set fire to the lute!

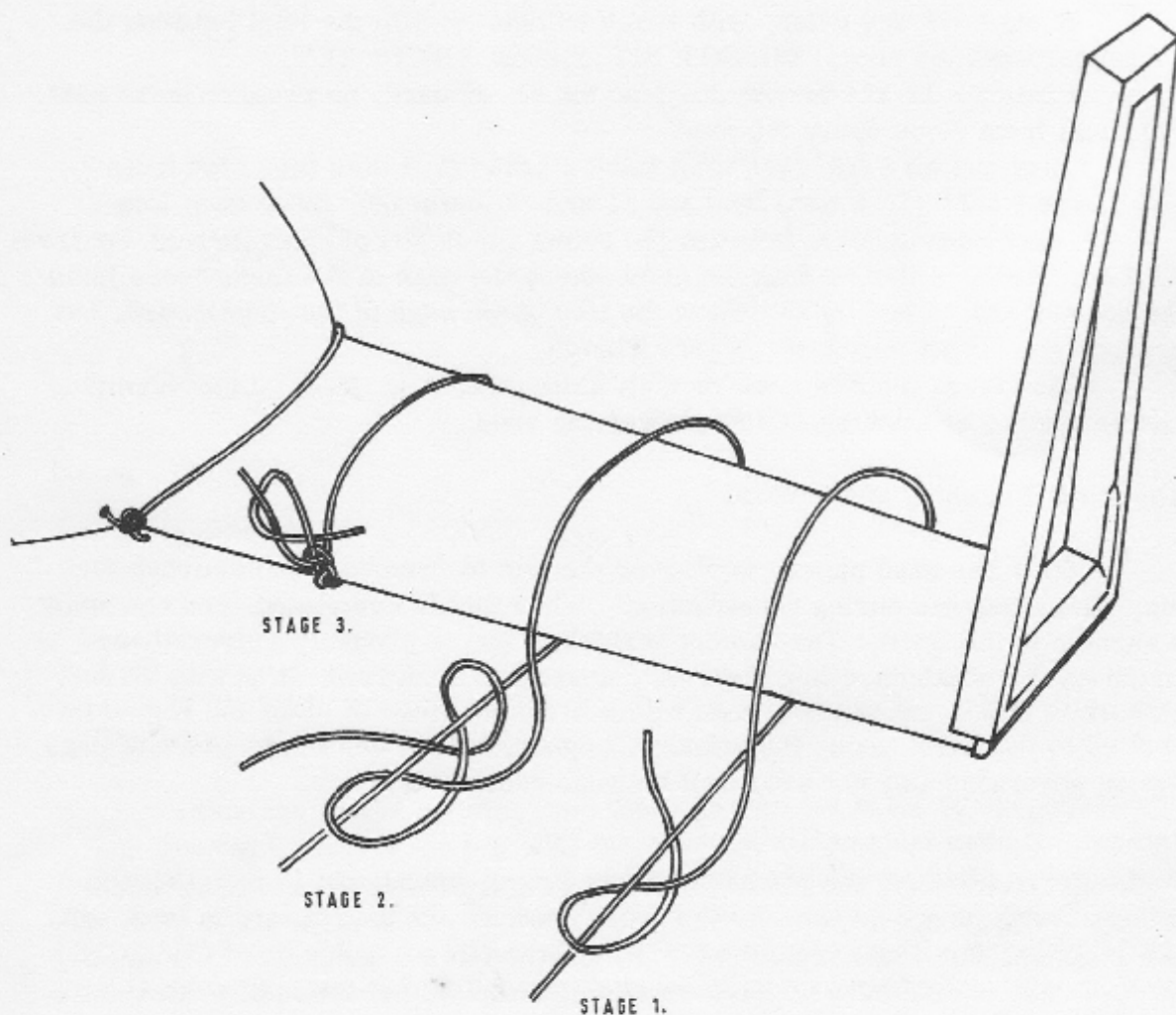

FIG. 13

30. Stringing

On the plan (Plan 3) you will see that we have numbered the strings 1 - 13 to correspond with the peg numbers.

Begin with the first treble string (1st course).

Insert peg No. 1 into the pegbox ready and commence by tying the string to the bridge as shown in Fig. 14. Holding the string tight so that the knot does not slip, take it up to the peg and thread through the hole. Turn the peg so that the string winds over the top and towards the thickest end of the peg. (Fig. 15). Locate the string in the correct groove of the fretnut and tighten it sufficiently to hold. If the string does not hold in the groove, deepen it slightly.

A little dry soap rubbed into the peg holes will allow the pegs to turn easily.

Repeat this procedure for all the strings.

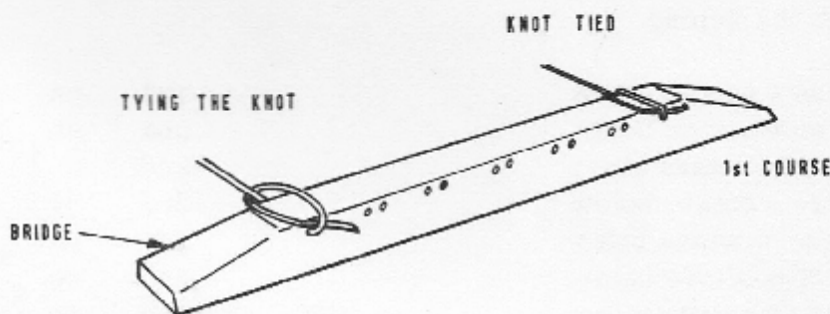

FIG. 14.

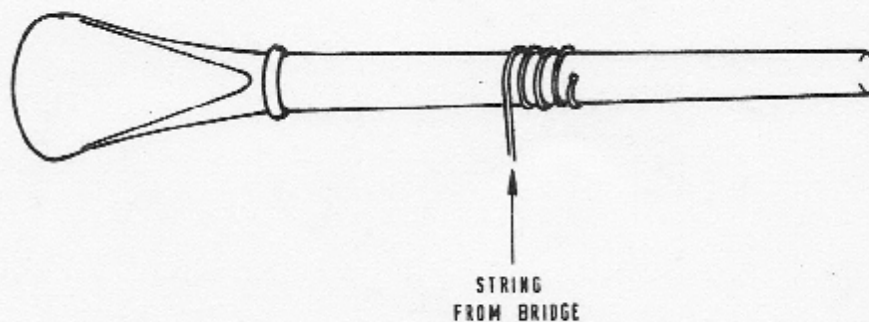

FIG. 15.

31. Tuning

The lute you have made has seven courses, a single string for the first course, and six pairs of strings making up the other six courses. The pairs of strings are tuned in unison. Here are the notes from the bass to the treble:- DD, GG, cc, ff, aa, d'd', g'.

The easiest way to tune the lute is to copy the notes from a keyboard instrument. Otherwise, you will need a standard 'A' tuning fork, which you can get from any music suppliers.

The tuning fork will give you the note an octave above the note required for the third course.

Tune as follows:

	FRET		STRING
3rd course = octave below an 'A' tuning fork			
2nd course =	5th	on	3rd
1st course =	5th	on	2nd
5th course = octave below	3rd	on	3rd
4th course =	5th	on	5th
6th course = octave below	2nd	on	4th
7th course = octave below	2nd	on	5th

32. To Check the Tuning

1st course = octave above	2nd	on	4th
6th course = octave below	2nd	on	4th
2nd course = octave above	2nd	on	5th
7th course = octave below	2nd	on	5th
3rd course = octave below	2nd	on	1st
4th course = octave below	3rd	on	2nd
5th course = octave below	3rd	on	3rd

Now you have completely finished your lute, and it is ready for you to play!